

# OPTICAL I/O CORE PAA-XW8001-ESB (Engineering Sample) 4-Channel Transmitter / Receiver Parallel Optical Modules

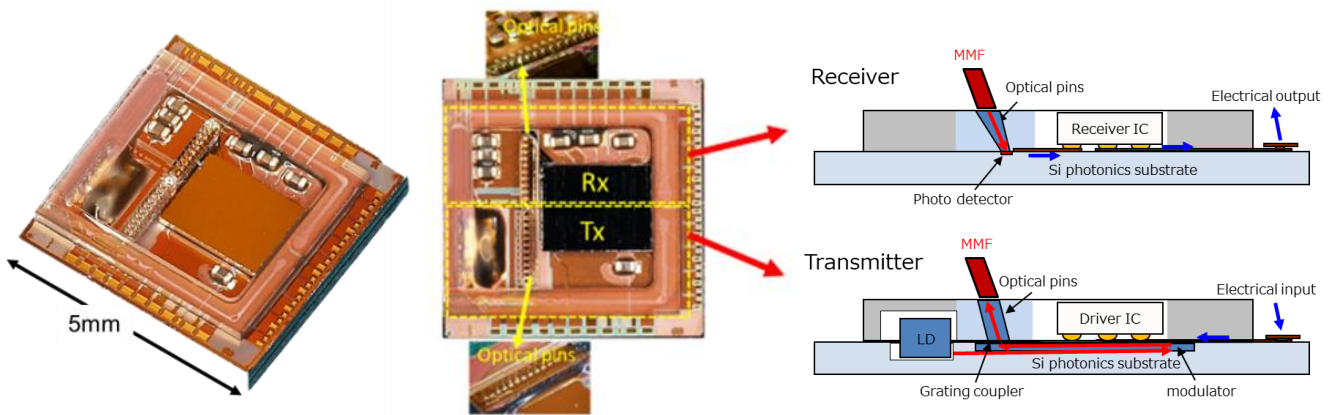

- 4 channel transmitter and 4 channel receiver Integrated module
- High Channel Capacity: 25Gbps x 4 Channels
- High density: 5.0 mm X 5.0 mm size.
- Low power consumption per Gbps: < 10 mW/Gbps for TX–RX pair
- 1.3-um Laser array in transmitter; PD array in receiver
- Three power supplies, 1.0 V, 1.1 V and 3.3 V
- Controlled by quasi-I2C
- -40 C to 85 C case temperature operating range (TBD)

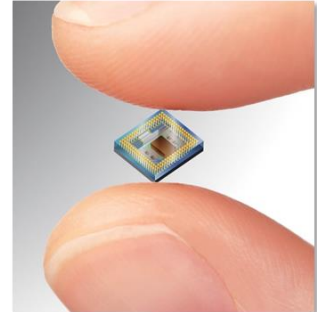

Structure of Optical I/O Core

## Transmitter / Receiver Block Diagram

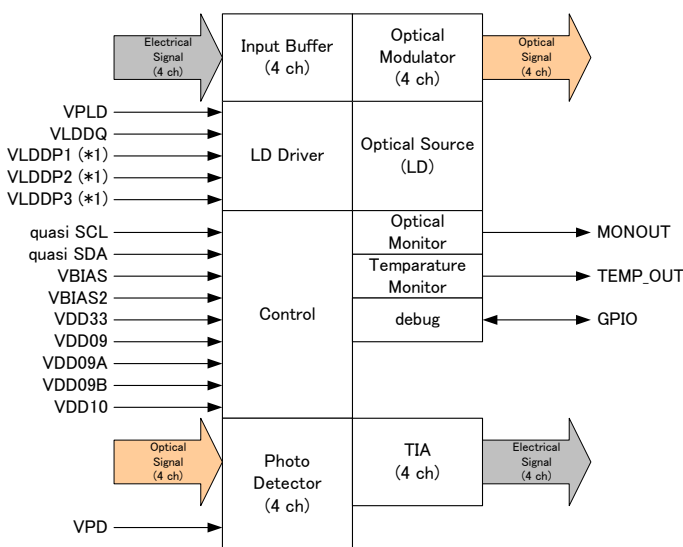

(\*1) When Internal LDD is not Hi-Z, keep these pins Hi-Z

## Transmitter Characteristics

Parameter	Symbol	Min	Typ	Max	Units	Ref.
Output Optical Power: Average			0	3.0	dBm	(TBD)
Output Optical Power: Disabled				-15	dBm	(TBD)
Extinction Ratio		3			dB	(TBD)
Output OMA: Squeighed			-3		dBm	(TBD)
Center Wavelength			(1300)		nm	
Eye Opening in Data Input Voltage (differential)		200		1200	mV (diff)	
Differential Input Impedance			100		ohm	
Differential Input Return Loss, 10M- 2.8GHz	Sdd11		18		dB	@2.8GHz(Sim)
Differential Return Loss, 2.8- 12.5 GHz	Sdd11		9.5		dB	@12.5GHz(Sim)

## Receiver Characteristics

Parameter	Symbol	Min	Typ	Max	Units	Ref.
Input Optical Power Sensitivity		-6			dBm	(TBD)
Data Output Differential Peak-to-Peak Voltage Swing			670		mVpp	(Eye Height)
Data Output Common Mode Voltage			760		mV	
Data Output Off State Differential					mVpp	
Data Output Off Common Mode					V	
Output Rise/Fall time (20-80%)			16/14		ps	
Receiver BW			13		GHz	
Differential Output Impedance			100		ohm	
Differential Output Return Loss, 10M- 2.8GHz	Sdd22		16		dB	
Differential Output Return Loss, 2.8GHz - 12.5 GHz	Sdd22		13.5		dB	

